



UNIVERSITY OF CAMBRIDGE INTERNATIONAL EXAMINATIONS
General Certificate of Education Ordinary Level

CANDIDATE
NAME

CENTRE
NUMBER

--	--	--	--	--

CANDIDATE
NUMBER

--	--	--	--



COMBINED SCIENCE

5129/22

Paper 2

October/November 2012

2 hours 15 minutes

Candidates answer on the Question Paper.

No Additional Materials are required.

READ THESE INSTRUCTIONS FIRST

Write your Centre number, candidate number and name on all the work you hand in.

Write in dark blue or black pen.

You may use a soft pencil for any diagrams, graphs or rough working.

Do not use staples, paper clips, highlighters, glue or correction fluid.

DO NOT WRITE IN ANY BARCODES.

Answer **all** questions.

A copy of the Periodic Table is printed on page 28.

At the end of the examination, fasten all your work securely together.

The number of marks is given in brackets [] at the end of each question or part question.

For Examiner's Use

--

This document consists of **24** printed pages.



1 Use words from the list to complete the sentences below.

- | | | | |
|---------------|---------------|---------------|---------------|
| blood | glands | kidney | liver |
| nerves | main | system | target |

Each word may be used once, more than once or not at all.

Hormones are chemicals that are produced by

Hormones are transported round the body by

Each hormone affects the activity of a part of the body which is called the
..... organ.

Hormones are destroyed by the [4]

2 (a) A weight of 2.5 N falls vertically through a distance of 2.4 m.

Calculate the work done on the weight by the force of gravity.

work done = unit [3]

(b) The falling weight is used to rotate a coil in a magnetic field.

An e.m.f. is induced across the ends of the coil.

State two factors that affect the magnitude of the induced e.m.f.

1.

2.

[2]

- 3 Fig. 3.1 shows the path of a ball thrown from the top of a building.

For
Examiner's
Use

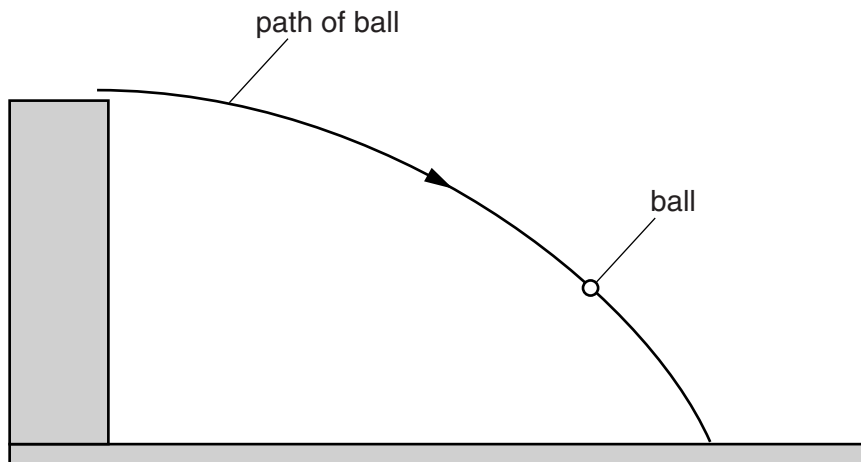

Fig. 3.1

The ball is shown at one position in its path.

- (a) On Fig. 3.1, draw an arrow to show the direction of the force of gravity acting on the ball. [1]
- (b) On the path of the ball shown in Fig. 3.1
- (i) mark where the ball has maximum potential energy and label this point **P**, [1]
 - (ii) mark where the ball has maximum kinetic energy and label this point **K**. [1]
- (c) The ball accelerates because of the force of gravity.

Explain what is meant by *acceleration*.

.....

..... [1]

4 Fig. 4.1 shows the electronic structure of a magnesium atom.

For
Examiner's
Use

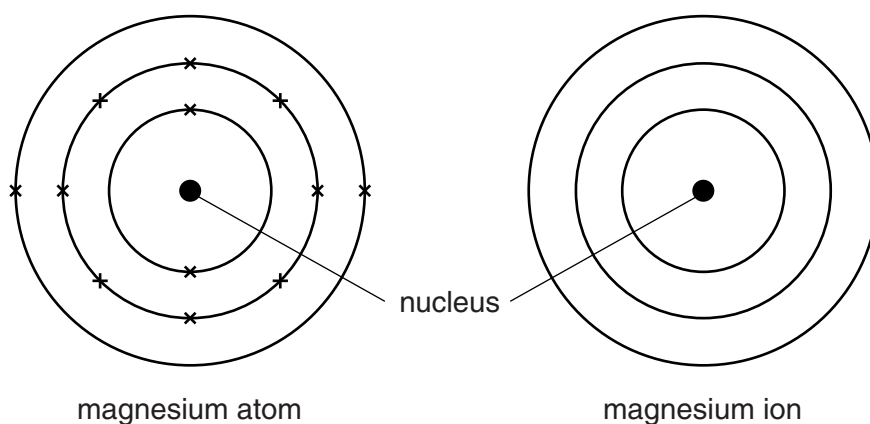

Fig. 4.1

(a) On Fig. 4.1, complete the electronic structure for the magnesium ion. [1]

(b) Magnesium burns in carbon dioxide to form magnesium oxide and carbon.

The equation for the reaction is



The relative molecular mass, M_r , of carbon dioxide is 44.

[A_r : Mg, 24; O, 16; C, 12]

Complete the following sentences.

44 g of carbon dioxide producesg of magnesium oxide andg of carbon.

4.4 g of carbon dioxide producesg of magnesium oxide andg of carbon.

1.1 g of carbon dioxide producesg of magnesium oxide. [4]

(c) Magnesium oxide is a white solid with a high melting point.

State the type of bonding present in magnesium oxide.

..... [1]

5 A path is made by laying concrete slabs side-by-side.

Small gaps are left between the slabs.

The gaps are filled with sand.

Fig. 5.1 shows the slabs on a cold day.

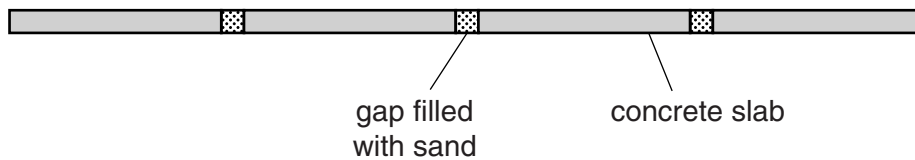

Fig. 5.1

(a) On a hot day, the gaps are smaller than on a cold day.

Explain why.

.....
 [1]

(b) Another path is laid on a cold day with no gaps between the concrete slabs.

Suggest what may happen to this path on a very hot day.

.....
 [1]

6 Fig. 6.1 shows an animal cell as seen using a microscope.

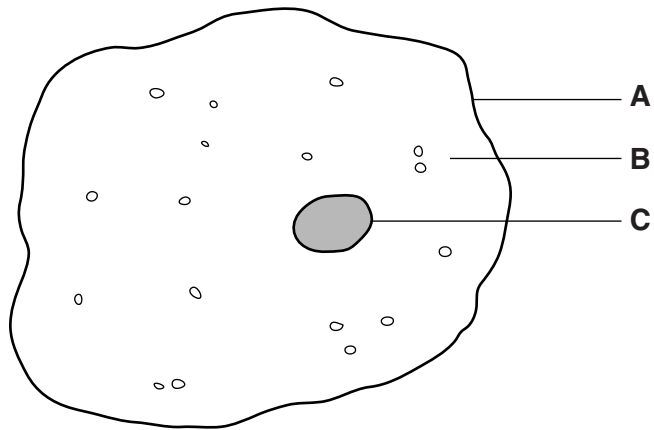

Fig. 6.1

(a) (i) In Table 6.1, name each of the labelled parts.

Table 6.1

letter	name
A	
B	
C	

[3]

(ii) State a function of part **A**.

.....

..... [1]

(b) The structure of a red blood cell is different from that of the cell shown in Fig. 6.1.

State **two** ways in which the structure is different.

Explain how each difference helps the red blood cell to carry out its function.

difference 1

explanation 1

difference 2

explanation 2

[6]

For
Examiner's
Use

- 7 Alpha-particles, beta-particles and gamma-rays are types of emission from radioactive sources.

For
Examiner's
Use

(a) State the type of emission that

(i) is the most penetrating, [1]

(ii) consists of two protons and two neutrons. [1]

(b) A nucleus emits a beta-particle.

State the change that occurs in the nucleus.

..... [1]

(c) A radioactive source is used in a laboratory experiment.

State two precautions that are taken to use the source safely.

1.

2.

[2]

8 Permanent magnets and electromagnets may be used to separate magnetic materials from non-magnetic materials.

(a) State a difference between magnetic materials and non-magnetic materials.

.....
..... [1]

(b) An electromagnet is used in a simple lock.

Fig. 8.1 shows part of this lock.

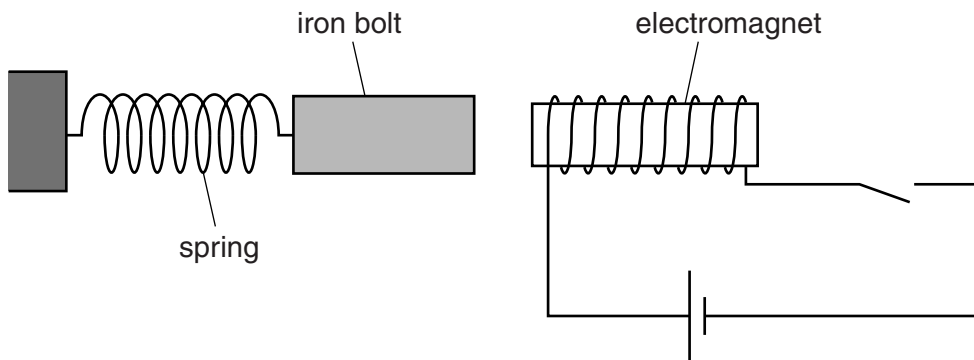

Fig. 8.1

When the current is switched on, the iron bolt is pulled towards the electromagnet to lock the door.

When the current is switched off, the spring pulls the iron bolt away from the electromagnet, unlocking the door.

(i) Suggest why the bolt is made of iron rather than steel.

.....
.....
..... [1]

(ii) The connections to the cell in Fig. 8.1 are reversed.

State the difference, if any, that this makes to the working of the lock.

.....
..... [1]

(iii) State **two** ways in which the strength of the electromagnet may be increased.

1.
2.

[2]

(c) Fig. 8.2 shows how the extension of the spring varies with the load on the spring.

For
Examiner's
Use

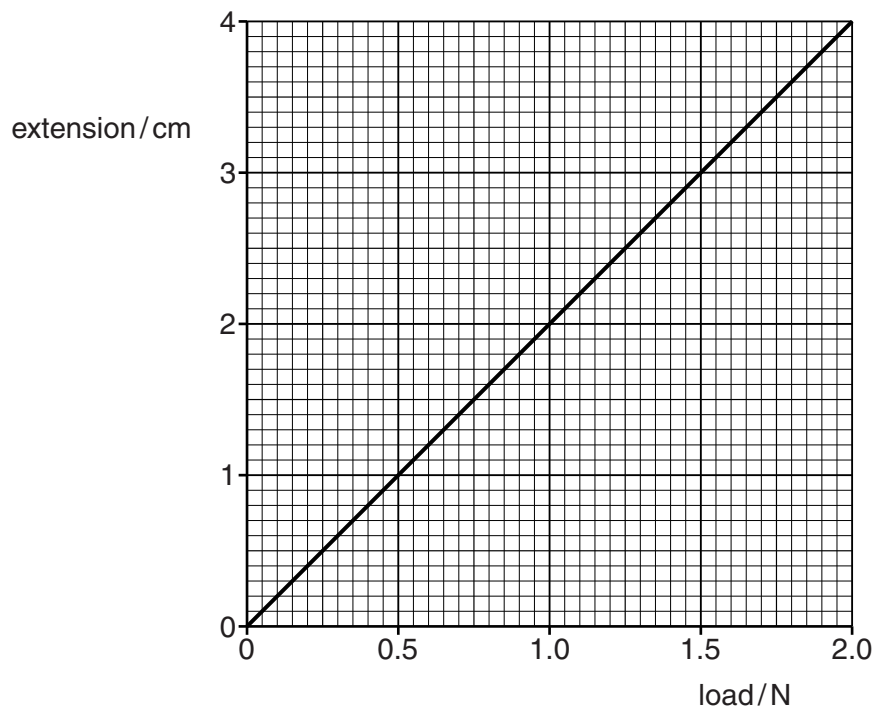

Fig. 8.2

Use Fig. 8.2 to find the load on the spring when it has an extension of 1.6 cm.

load = N [1]

9 Study the reaction scheme shown in Fig. 9.1.

For
Examiner's
Use

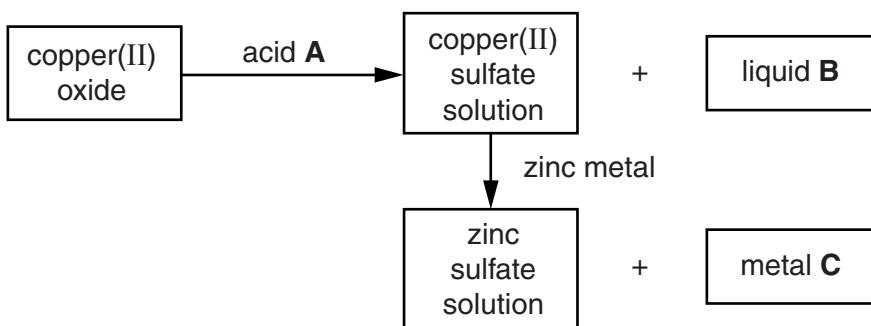

Fig. 9.1

(a) Identify **A**, **B** and **C**.

acid **A**

liquid **B**

metal **C**

[3]

(b) Describe how copper(II) sulfate crystals may be obtained from the copper(II) sulfate solution.

.....

 [2]

(c) State **two** general physical properties of substance **C** that show it is a metal.

1.

2.

[2]

10 In an experiment, 20 seeds of the same species are placed in each of four tubes as shown in Fig. 10.1.

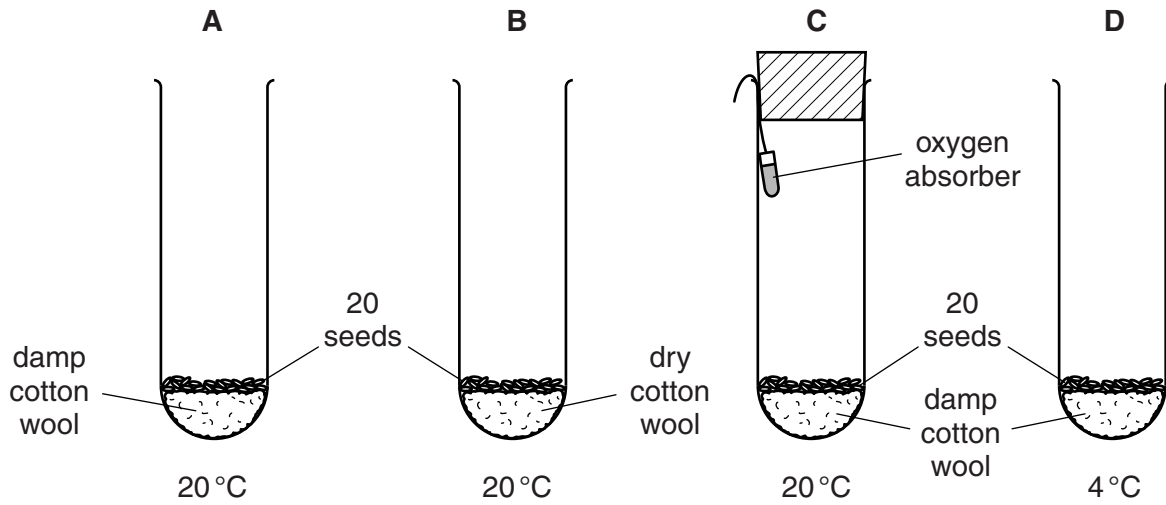

Fig. 10.1

The conditions for each set of seeds are shown in Fig. 10.1.

(a) Suggest why more than one seed is used in each tube.

.....
 [1]

(b) After several days, all the seeds in tube A germinate.

None of the seeds in tubes B, C or D germinate.

(i) Suggest a change that could be made to tube B so that the seeds germinate.

.....
 [1]

(ii) State a reason why germination does not occur in tube C.

Explain your answer.

reason

explanation

..... [2]

(iii) State a reason why germination does not occur in tube **D**.

Explain your answer.

reason

explanation

.....

[2]

*For
Examiner's
Use*

11 Fig. 11.1 shows a series circuit.

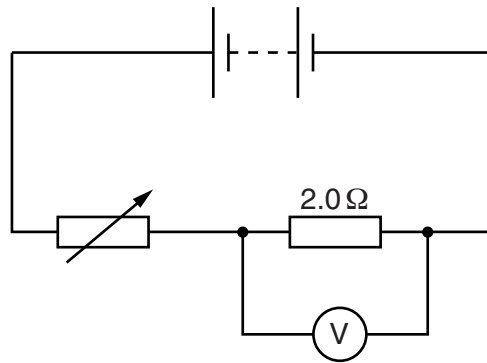

Fig. 11.1

A voltmeter measures the potential difference (p.d.) across the 2.0 Ω resistor.

(a) The variable resistor is adjusted so that the voltmeter reads 1.0V.

(i) Calculate the current in the 2.0 Ω resistor.

current = A [2]

(ii) The p.d. across the battery terminals is 5.0V.

The voltmeter reads 1.0V.

Calculate the p.d. across the variable resistor.

p.d. = V [1]

(b) The resistance of the variable resistor is increased.

State what happens, if anything, to

(i) the current in the variable resistor, [1]

(ii) the p.d. across the 2.0 Ω resistor. [1]

12 Fig. 12.1 shows the apparatus used to pass steam over heated zinc.

For
Examiner's
Use

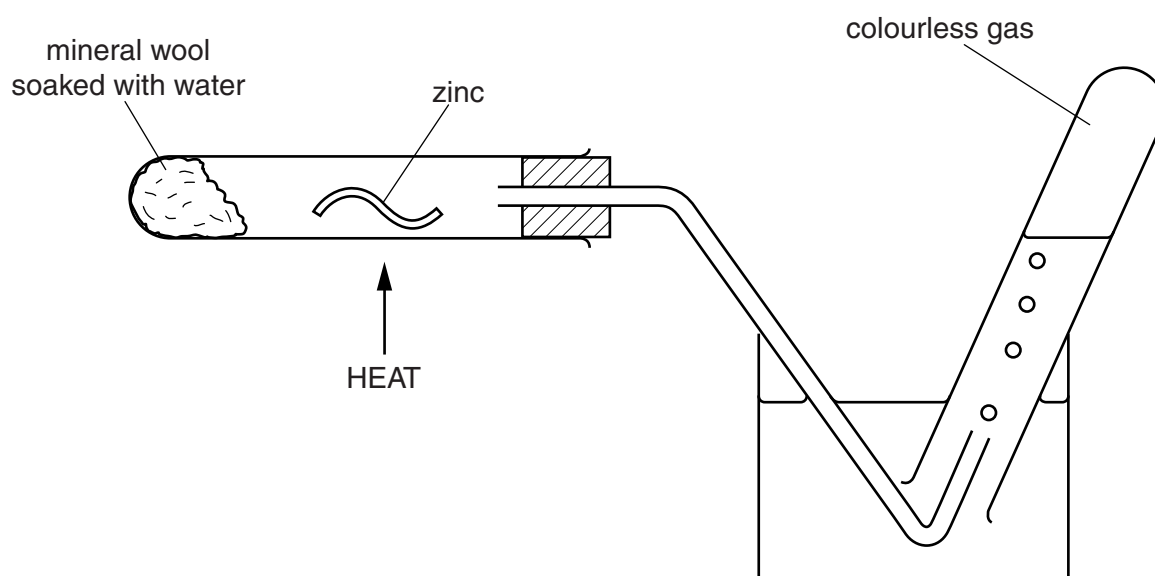
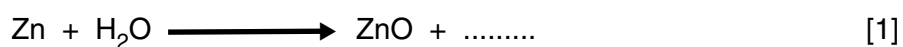

Fig. 12.1

The products of the reaction are zinc oxide and a colourless gas.

(a) Complete the equation for the reaction.



(b) Explain how the equation in (a) shows that zinc is oxidised and steam is reduced during the reaction.

.....

 [2]

(c) Zinc is used to prevent iron from rusting.

(i) State the name of each of the two substances in air which cause iron to rust.

..... and [2]

(ii) State the name of the process where iron is treated with zinc to prevent rusting.

..... [1]

13 Five similar fields are used for growing maize. They are treated with different quantities of nitrogen-containing fertiliser.

For
Examiner's
Use

The quantities of fertiliser added and the crop yields are shown in Fig. 13.1.

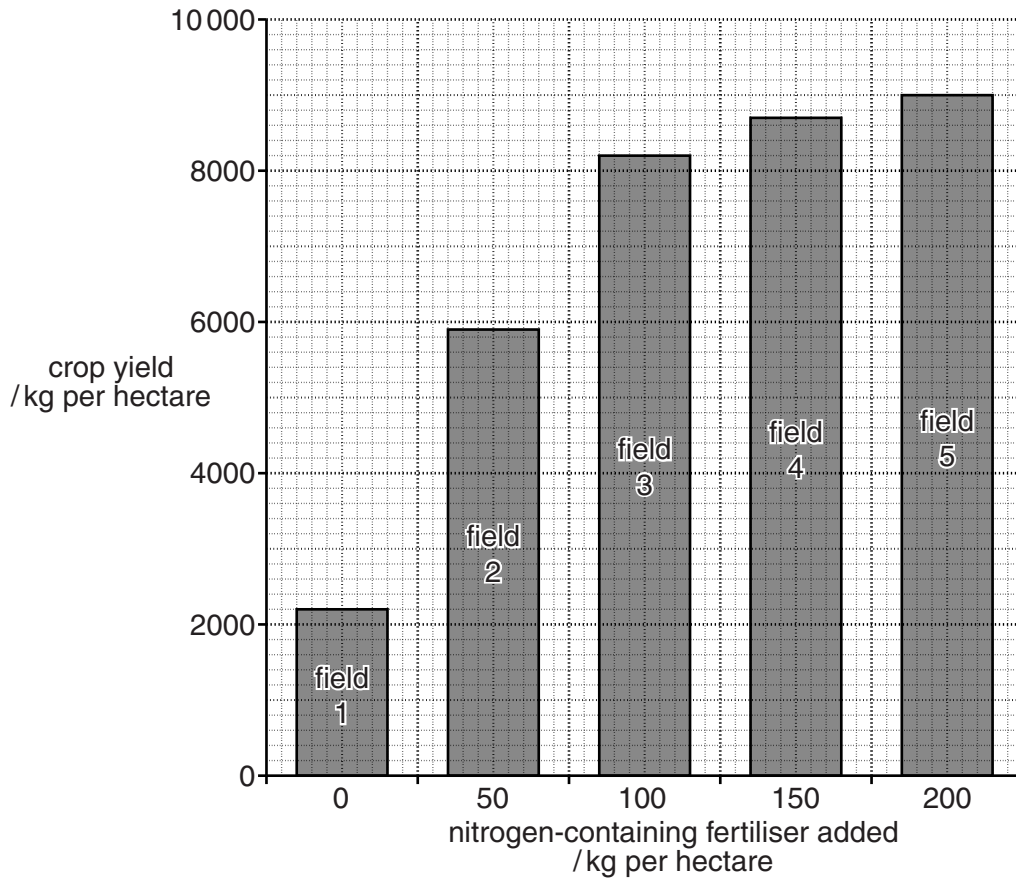

Fig. 13.1

(a) Explain how nitrogen-containing ions are able to pass from soil into a plant.

.....

.....

..... [2]

(b) (i) Using Fig. 13.1, state the crop yield when no nitrogen-containing fertiliser is added.

..... kg per hectare [1]

- (ii) Calculate the **increase** in crop yield when 100 kg per hectare of nitrogen-containing fertiliser is used, rather than 50 kg per hectare.

Show your working.

..... kg per hectare [2]

- (iii) Explain why the addition of nitrogen-containing fertiliser produces an increase in the yield of maize.

.....
.....
.....
..... [2]

- (iv) Use Fig. 13.1 to suggest the crop yield when 250 kg per hectare of nitrogen-containing fertiliser is used.

..... kg per hectare [1]

- (c) Explain why most forms of life are dependent on plants carrying out photosynthesis.

.....
.....
.....
..... [2]

14 The first member of the alkene homologous series is ethene.

Ethene is an unsaturated hydrocarbon.

For
Examiner's
Use

(a) State the general formula of the alkenes.

..... [1]

(b) Ethene reacts with hydrogen to form ethane.

(i) State the type of reaction that takes place when ethene reacts with hydrogen.

..... [1]

(ii) State, in terms of bonds, how the structure of ethene differs from ethane.

..... [1]

(c) Ethene undergoes polymerisation to form poly(ethene).

Draw the structure of poly(ethene).

[2]

15 (a) What is coronary heart disease?

..... [1]

(b) State **two** causes of coronary heart disease.

1.

.....

2.

.....

[2]

16 Fig. 16.1 shows a vernier scale and a micrometer scale.

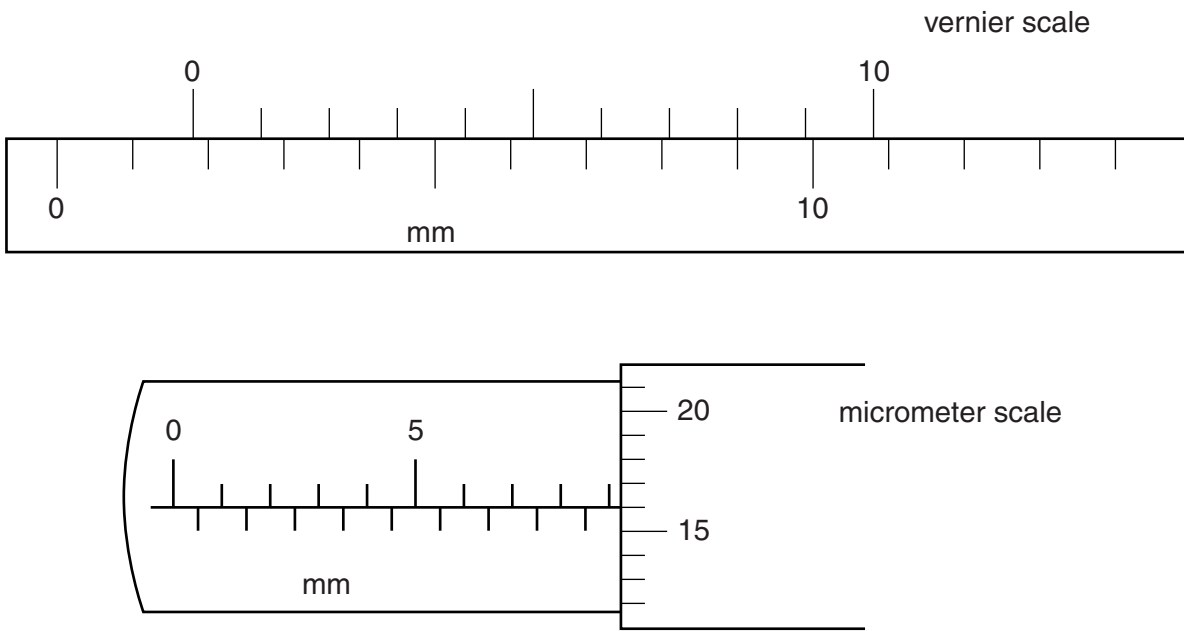

Fig. 16.1

- (a) The reading on the vernier scale ismm. [1]
- (b) The reading on the micrometer scale ismm. [1]

- 17 A bar is placed on a pivot and blocks of mass m_1 and m_2 are placed on the bar, as shown in Fig. 17.1.

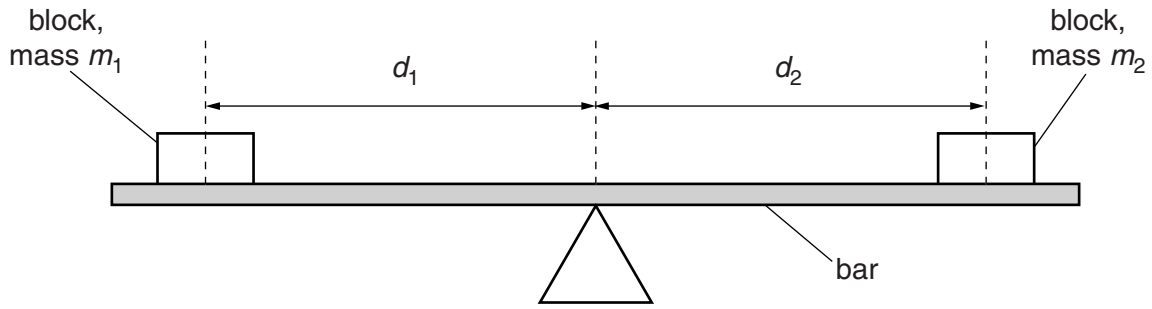

Fig. 17.1

The bar is horizontal.

The distances d_1 and d_2 of the blocks from the pivot are shown in Fig. 17.1.

The masses and their distances from the pivot may be changed so that the bar stays horizontal, tips clockwise or tips anticlockwise.

Fig. 17.2 shows the bar tipping anticlockwise.

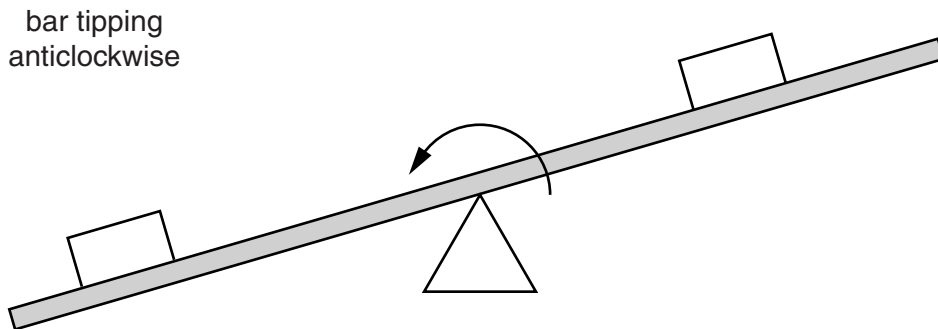

Fig. 17.2

Different masses m_1 and m_2 and distances d_1 and d_2 are shown in Table 17.1.

Complete Table 17.1 by stating whether the bar is horizontal, tips clockwise or tips anticlockwise. The first line has been completed for you.

For
Examiner's
Use

Table 17.1

m_1/g	d_1/cm	m_2/g	d_2/cm	horizontal, tips clockwise, tips anticlockwise.
20	15	20	15	horizontal
20	15	20	20	
30	15	20	15	
10	15	5	15	
30	10	25	12	

[2]

- 18 (a) Phosphine contains phosphorus and hydrogen and has the formula PH_3 .

Phosphorus is in Group V of the Periodic Table.

Complete Fig. 18.1 to show the arrangement of the outer-shell electrons in a molecule of phosphine.

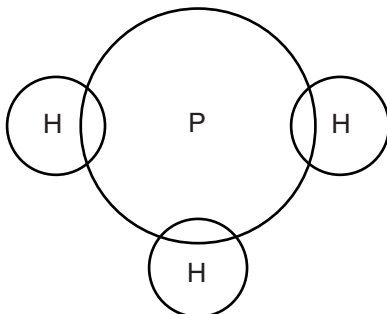

Fig. 18.1

[2]

- (b) Complete the following sentences.

The type of bonding present in phosphine is

Compounds with this type of bonding have melting

points and are formed when a combines with a

.....

[3]

19 Fig. 19.1 shows a pin in front of a plane mirror.

A ray of light is incident on the mirror as shown.

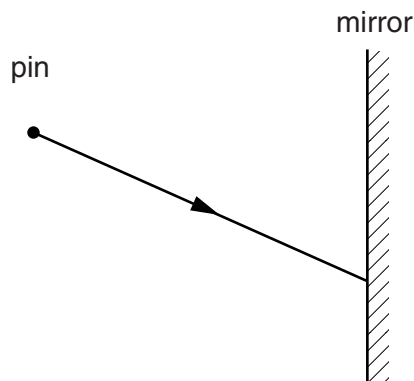

Fig. 19.1

On Fig. 19.1,

- (a) draw the normal at the point where the ray is incident on the mirror, [1]
- (b) draw the reflected ray, [1]
- (c) mark the position of the image of the pin with an X. [1]

20 The following is a list of gases.

acetylene	ammonia	carbon dioxide	carbon monoxide
ethane	nitrogen	oxygen	sulfur dioxide

Use the list to complete the following sentences.

Each gas may be used once, more than once or not at all.

- (a) The gas produced by complete combustion of hydrocarbon fuels is [1]
- (b) The gases used in welding are and [1]
- (c) The gas that makes up most of the air is [1]
- (d) The gas that turns Universal Indicator red is [1]

Permission to reproduce items where third-party owned material protected by copyright is included has been sought and cleared where possible. Every reasonable effort has been made by the publisher (UCLES) to trace copyright holders, but if any items requiring clearance have unwittingly been included, the publisher will be pleased to make amends at the earliest possible opportunity.

University of Cambridge International Examinations is part of the Cambridge Assessment Group. Cambridge Assessment is the brand name of University of Cambridge Local Examinations Syndicate (UCLES), which is itself a department of the University of Cambridge.

DATA SHEET The Periodic Table of the Elements

		Group																																			
		I	II	III	IV	V	VI	VII	0																												
		<table border="1" style="margin: auto; border-collapse: collapse;"> <tr> <td style="text-align: center;">1 H Hydrogen 1</td> </tr> </table>										1 H Hydrogen 1																									
1 H Hydrogen 1																																					
		<table border="1" style="margin: auto; border-collapse: collapse;"> <tr> <td style="text-align: center;">4 He Helium 2</td> </tr> </table>										4 He Helium 2																									
4 He Helium 2																																					
7 Li Lithium 3	9 Be Beryllium 4																																				
23 Na Sodium 11	24 Mg Magnesium 12																																				
39 K Potassium 19	40 Ca Calcium 20	45 Sc Scandium 21	48 Ti Titanium 22	51 V Vanadium 23	52 Cr Chromium 24	55 Mn Manganese 25	56 Fe Iron 26	59 Co Cobalt 27	59 Ni Nickel 28	64 Cu Copper 29	65 Zn Zinc 30	70 Ga Gallium 31	73 Ge Germanium 32	75 As Arsenic 33	79 Se Selenium 34	80 Br Bromine 35	84 Kr Krypton 36																				
85 Rb Rubidium 37	88 Sr Strontium 38	89 Y Yttrium 39	91 Zr Zirconium 40	93 Nb Niobium 41	96 Mo Molybdenum 42	101 Ru Ruthenium 44	103 Rh Rhodium 45	106 Pd Palladium 46	108 Ag Silver 47	112 Cd Cadmium 48	115 In Indium 49	119 Sn Tin 50	122 Sb Antimony 51	128 Te Tellurium 52	127 I Iodine 53	131 Xe Xenon 54																					
133 Cs Caesium 55	137 Ba Barium 56	139 La Lanthanum 57	178 Hf Hafnium 72	181 Ta Tantalum 73	184 W Tungsten 74	190 Os Osmium 76	192 Ir Iridium 77	195 Pt Platinum 78	197 Au Gold 79	201 Hg Mercury 80	204 Tl Thallium 81	207 Pb Lead 82	209 Bi Bismuth 83	209 Po Polonium 84	210 At Astatine 85	222 Rn Radon 86																					
223 Fr Francium 87	226 Ra Radium 88	227 Ac Actinium 89																																			
		<table border="1" style="margin: auto; border-collapse: collapse;"> <tr> <td style="text-align: center;">140 Ce Cerium 58</td> <td style="text-align: center;">141 Pr Praseodymium 59</td> <td style="text-align: center;">144 Nd Neodymium 60</td> <td style="text-align: center;">147 Pm Promethium 61</td> <td style="text-align: center;">150 Sm Samarium 62</td> <td style="text-align: center;">152 Eu Europium 63</td> <td style="text-align: center;">157 Gd Gadolinium 64</td> <td style="text-align: center;">162 Dy Dysprosium 66</td> <td style="text-align: center;">165 Ho Holmium 67</td> <td style="text-align: center;">167 Er Erbium 68</td> <td style="text-align: center;">169 Tm Thulium 69</td> <td style="text-align: center;">173 Yb Ytterbium 70</td> <td style="text-align: center;">175 Lu Lutetium 71</td> </tr> <tr> <td style="text-align: center;">232 Th Thorium 90</td> <td style="text-align: center;">231 Pa Protactinium 91</td> <td style="text-align: center;">238 U Uranium 92</td> <td style="text-align: center;">237 Np Neptunium 93</td> <td style="text-align: center;">244 Pu Plutonium 94</td> <td style="text-align: center;">243 Am Americium 95</td> <td style="text-align: center;">247 Cm Curium 96</td> <td style="text-align: center;">251 Cf Californium 98</td> <td style="text-align: center;">252 Es Einsteinium 99</td> <td style="text-align: center;">257 Fm Fermium 100</td> <td style="text-align: center;">258 Md Mendelevium 101</td> <td style="text-align: center;">259 No Nobelium 102</td> <td style="text-align: center;">260 Lr Lawrencium 103</td> </tr> </table>										140 Ce Cerium 58	141 Pr Praseodymium 59	144 Nd Neodymium 60	147 Pm Promethium 61	150 Sm Samarium 62	152 Eu Europium 63	157 Gd Gadolinium 64	162 Dy Dysprosium 66	165 Ho Holmium 67	167 Er Erbium 68	169 Tm Thulium 69	173 Yb Ytterbium 70	175 Lu Lutetium 71	232 Th Thorium 90	231 Pa Protactinium 91	238 U Uranium 92	237 Np Neptunium 93	244 Pu Plutonium 94	243 Am Americium 95	247 Cm Curium 96	251 Cf Californium 98	252 Es Einsteinium 99	257 Fm Fermium 100	258 Md Mendelevium 101	259 No Nobelium 102	260 Lr Lawrencium 103
140 Ce Cerium 58	141 Pr Praseodymium 59	144 Nd Neodymium 60	147 Pm Promethium 61	150 Sm Samarium 62	152 Eu Europium 63	157 Gd Gadolinium 64	162 Dy Dysprosium 66	165 Ho Holmium 67	167 Er Erbium 68	169 Tm Thulium 69	173 Yb Ytterbium 70	175 Lu Lutetium 71																									
232 Th Thorium 90	231 Pa Protactinium 91	238 U Uranium 92	237 Np Neptunium 93	244 Pu Plutonium 94	243 Am Americium 95	247 Cm Curium 96	251 Cf Californium 98	252 Es Einsteinium 99	257 Fm Fermium 100	258 Md Mendelevium 101	259 No Nobelium 102	260 Lr Lawrencium 103																									

* 58–71 Lanthanoid series
† 90–103 Actinoid series

a	X
b	b

Key
 a = relative atomic mass
 X = atomic symbol
 b = atomic (proton) number

The volume of one mole of any gas is 24dm³ at room temperature and pressure (r.t.p.).